

# NEXTSTEP



MH67214  
DOSING PUMP  
NSF/ANSI/CAN 61

EN



MULTIFUNCTION METERING PUMP  
STEPPER MOTOR DRIVEN



# TABLE OF CONTENTS

GENERAL SAFETY GUIDELINES .....	3	10.2 connection diagrams .....	35
PURPOSE OF USE AND SAFETY .....	4	11. MAINTENANCE .....	36
ENVIRONMENTAL SAFETY .....	5	11.1 Maintenance schedule .....	36
LABEL .....	5	11.2 Maintenance inspection .....	36
SPARE PARTS .....	5	11.3 Shutdown procedure .....	37
1. DESCRIPTION .....	7	11.4 Display battery replacement procedure .....	37
1.1 Nexstep Series .....	7	12. TROUBLESHOOTING .....	38
1.2 Working modes .....	7	13. FLOW CURVES .....	39
1.3 Functions .....	8		
1.4 Capacities .....	8		
1.5 Features .....	9		
1.6 Unpacking .....	10		
1.7 List of materials .....	10		
2. PRODUCT DESCRIPTION .....	11		
2.1 Control elements .....	11		
2.1 Pump head .....	12		
2.3 Dimensions .....	13		
3. INSTALLATION .....	15		
3.1 How to install metering pump .....	15		
3.2 User health and safety .....	15		
3.3 The work area .....	15		
3.4 Pump location .....	15		
2.5 Requirements for product positioning .....	15		
3.6 Installation drawings .....	16		
4. PIPING CONNECTIONS .....	17		
4.1 Foot filter / Level probe .....	17		
4.2 Suction hose connection .....	18		
4.3 Pump head / delivery hose assembling procedure .....	18		
4.4 Injection valve .....	19		
4.5 Venting hose .....	19		
5. ELECTRICAL WIRINGS .....	20		
5.1 Preliminary checks .....	20		
6. CONNECTIONS .....	21		
7. START UP .....	22		
7.1 Start up .....	22		
8. PRIMING .....	23		
8.1 Precautions .....	23		
8.2 Priming .....	23		
9. SET UP .....	24		
9.1 Basic principle .....	24		
9.2 Display icon .....	24		
9.3 Menu overview .....	25		
9.4 Pump capacity setting .....	33		
10. ELECTRICAL WIRING .....	35		
10.1 Preliminary checks .....	35		



Read these operating instructions carefully before use and follow instructions during use. These operating instructions contain important safety information, and failure to follow them may result in improper product performance, serious injuries, including death, damage to the equipment and/or property damage. . Keep these instructions for future reference.  
NOTE: These instructions are subject to change without notice.



**NORME CE**  
**EC RULES (STANDARD EC)**  
**NORMAS DE LA CE**

Direttiva Bassa Tensione } **2014/35/UE**  
Low Voltage Directive  
Directiva de baja tensión

Direttiva EMC Compatibilità Elettromagnetica } **2014/30/UE**  
EMC electromagnetic compatibility directive  
EMC directiva de compatibilidad electromagnética





Norme armonizzate europee nell'ambito della direttiva } **2006/42/CE**  
European harmonized standards underdirective  
Las normas europeas armonizadas conforme a la directiva

**GENERAL SAFETY GUIDELINES**

Failure to operate, install or maintain the unit in accordance with this manual may result in and failure to follow them may result in improper product performance, serious injuries, including death, damage to the equipment and/or property damage.

**ICONS**

This manual use the following safety message icon:

-  **Warning!**  
Indicates a hazardous situation which, if not avoided, will result in death or serious injury.
-  **Warning!**  
Indicates a hazardous situation which, if not avoided, could result in death or serious injury.
-  **Important** - A practice not related to personal injury or additional information.
-  **Cross reference** - An instance which refers to related information elsewhere in the same document.

 **AC - Alternating current**

 **Protective earth**













 **DC - Direct current**

 **Stand-by**

**METERING PUMP IS INTENDED FOR CHEMICAL DOSING AND DRINKING WATER  
TREATMENT.**

Do not use in explosive area (EX).  
Do not use with flammable chemicals.  
Do not use with radioactive chemicals.

Use after a proper installation. Follow the instructions for use for proper installation. Use the pump in accordance with the data and specifications printed on the label.  
Do not modify or use in a manner inconsistent with the provisions of the operating manual.

-  **Keep the pump protected from sun and water. Avoid water splashes.**
-  **In the event of an emergency, switch off the the pump immediately. Disconnect the power cable from the power supply.**
-  **When using pump with aggressive chemicals, observe the regulations concerning the transport and storage of aggressive fluid. Wear protective clothing as well.**
-  **When installing, always follow any applicable national regulations and/or standards.**
-  **Manufacturer is not liable for any unauthorized use or misuse of this product that may cause and unauthorized use or misuse may result in improper product performance, serious injuries, including death, damage to the equipment and/or property damage.**
-  **Pump must be accessible at all times for both operating and servicing. Do not obstruct access to pump in any way.**
-  **Never operate the pumping system with a blocked suction and discharge. Take all necessary measures to avoid this condition.**
-  **Feeder should be interlocked with a no-flow protection device to automatically shut-off the pumps when there is no flow.**
-  **Take appropriate measures to prevent cross connection of chemicals!**
-  **Chemical feeding must be stopped during backwash cycles and periods of no-flow as these conditions may introduce the potential for chemical overdosing. Failure to do so may result in elevated chemical concentrations and hazardous gas introduction into the pool or spa. This could lead to improper product performance, serious injuries, including death, damage to the equipment and/or property damage. Pump. and accessories must be serviced and repaired by qualified and authorized personnel only. Failure to service and repair the pump and accessories in accordance with this manual may result in improper product performance, serious injuries, including death, damage to the equipment and/or property damage.**
-  **Before any operation:**
  - Always read chemical Material Safety Data Sheet (MSDS) for chemical being used with pump;
  - always wear protective clothing;
  - always discharge the liquid end before servicing the pump.
  - empty and rinse the liquid end before working on a pump that has been used with hazardous or unknown chemicals.
-  **This equipment requires regular maintenance to ensure potability requirements of the water and maintenance of improvements as declared by the manufacturer. Failure to maintain the pump and accessories in accordance with this manual may result in improper product performance, serious injuries, including death, damage to the equipment and/or property damage.**

**Work area**

Always keep the pump area clean to avoid and/or discover emissions.

**Recycling guidelines**

**EWC code: 16 02 14**

Always recycle according to these guidelines:

1. If the unit or parts are accepted by an authorized recycling company, then follow local recycling laws and regulations.
2. If the unit or parts are not accepted by an authorized recycling company, then return them to the nearest representative.

**Waste and emissions regulations**

Observe all applicable safety regulations regarding waste and emissions:

- Dispose appropriately of all waste.
- Handle and dispose of the dosed chemical in compliance with applicable environmental regulations.
- Clean up all spills in accordance with safety and environmental procedures.
- Report all environmental emissions to the appropriate authorities.

**LABEL**

Fig. 1. Product label.

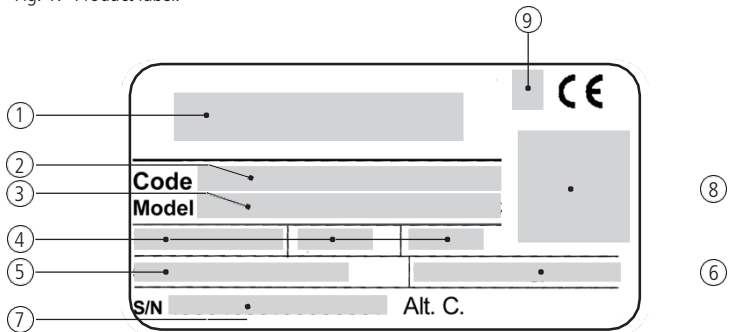

No.	DESCRIPTION
1	Manufacturer
2	Code
3	Model
4	Voltage supply/frequency - Ampere - protection class
5	Maximum pressure
6	Maximum capacity
7	Serial number
8	Data matrix
9	UL conformity (if any)

**Spare parts**

For spare parts orders or any other communication, refer to product label. Code (CODE) and serial number (S / N) uniquely identify the pump.

**i** Improper transportation or storage may result in improper product performance, serious injuries, including death, damage to the equipment and/or property damage.

Use original box to pack the pump.

**!** Observe storage conditions also for transportation.

Although packed, always protect the unit against humidity and the action of chemicals.

Do not discard packaging. Use it to repackage the pump.

Transportation and storage temperature ..... 10 / 50°C (32 / 122°F)  
Humidity ..... 95% relative humidity (not condensed)

## 1. DESCRIPTION

### 1.1 NEXSTEP Series

NextStep is a mechanically actuated, stepper motor driven diaphragm dosing pump with multiple control functions. The microprocessor controlled stepper motor ensures a homogeneous dosing process.

The position and the speed of the diaphragm is controlled by the microprocessor electronics during the entire discharge/suction cycle.

The slow mode enables reduction of the suction speed. Thereby, viscous liquids can be dosed more easily and more accurately. When slow motion mode is activated, the maximum delivery rate of the dosing pump is also reduced.

- STAND-BY input
- LEVEL (level control) input
- ALARM contact output.
- MODBUS / 4-20mA output options

** Some functions described into this manual may need accessories not included in the pump packaging.**

## 1.2 Working modes

Pump can work in different ways:

MODE	WORKING MODES
CONSTANT	Pump doses at a constant rate set in "LPH" (liters per hour) or GPH (gallons per hour), during setup session.
OZ PER PULSE	The pump doses the quantity of product set for each impulse received.
PPM	Dosing rate is determined by pulses from a water meter based on a PPM setpoint and chemical product concentration (%).
PERCENTAGE	Dosing rate is determined by pulses from a water meter based on a percentage (%) setpoint and chemical product concentration (%).
MLQ	Dosing rate is determined by pulses from a water meter based on aMLQ (milliliters per quintal) setpoint and chemical product concentration (%).
BATCH	A signal from either an external contact or manual trigger on the pump starts the pump to dose the set quantity.
VOLT	Voltage from an external device drives the pump to dose proportionally using a minimum and maximum flow range. (0–10 VDC).
mA	Current from an external device drives the pump to dose proportionally using a minimum and maximum flow range.
PULSE	Pump doses proportionally between the low and high p/m values. This mode is used with controllers that provide a pulse output.
PAUSE-WORK	Pump doses the set quantity during working time.
WEEKLY PROGRAMMING	This mode is used for weekly program pump dosing activity.

Regardless of the above selected working mode, EXT CONSTANT will start or stop the pump by means of the "external constant" contact input.

EXT CONSTANT & STANDBY	This operating mode is enabled in the More menu (EXTERNAL INPUT). An external signal starts constant dosing of a certain amount per hour (QUANTITY) at the set speed. In this case, the working mode displayed is EXT CONSTANT. Contact can be set N.O. or N.C. For STANDBY, an external input will stop the pump. Contacts can be set N.O. or N.C
------------------------	--

## 1.3 Functions

FUNCTION	ICON	DESCRIPTION
SLOWMODE	100%  ...% ...% 1%	Slow mode enables reduction of the suction speed. Thereby, viscous liquids can be dosed more easily and more accurately. When slow mode is reduced (from 100% to 30%, the maximum delivery rate of the dosing pump is also reduced. To enable Slow Mode: SETTINGS / MORE / Pump capacity / Slow mode
COLOR STATUS DISPLAY	green display	pump is running
	white display	stand-by mode
	yellow display	warning condition
	red display	alarm condition

## 1.4 Specs

MODEL	NS1	NS2	NS3	NS4	NS5	NS6	NS7	NS8	NS9
Flow GPH	0.5	1.3	2	3.4	5.3	7.4	13.2	18.4	21.1
Pressure Max PSI	362	290	232	145	101	72	58	43	29

## 1.5 Features

ELECTRICAL	
Power supply	100-240 Vac - 50/60 Hz / 9-36VDC* <span style="float: right;">*see pump's label</span>
Power consumption	30 W
Alarm output	Dry contact relay

MATERIALS	
Diaphragm	PTFE
Case	NOVABLEND PC/ABS T110 FR
Pump head (available)	PVDF

MECHANICAL	
Spring return mechanism	
Bleed valve valve	Manual
Double ball check valve	
Capacity Control	

Environment temperature	10-45 °C / 55-113 °F
Chemical temperature	0-50 °C/ 32-122 °F
Installation class	II
Protection degree	IP 65 (% working RU: 85% T<=40°C; 70% T=50°C - without condensing water)
Max suction height	5 FT (1,5 m)
Dosing accuracy	± 1% at the rated pressure

## 1.6 Unpacking

QUANTITY	Description	(PVDF)	(PP/PVC)	(SS)
4	4.5mm x 40mm self-tapping screws	●	●	●
1	5 X 20 delayed fuse	●	●	●
1	level probe with foot valve/strainer (PVDF)	●	●	
1	4 psi injection valve (PVDF)	● 1/2" or 3/4"	● 1/2"	● 3/4" STAINLESS STEEL
1	6.5 FT (2M) Discharge tubing <sup>1</sup>	● PVDF	● PVDF	● PE
1	6.5 FT (2M) Suction tubing <sup>1</sup>	● PVC	● PE	● PVC
1	6.5FT (2M) Venting tubing	● PVC	● PE	
1	8 FT (2.5M) external signal cable	●	●	●
1	6.5FT (2M) stand-by/alarm cable	●	●	●
1	Operating manual	●	●	●

<sup>1</sup> If the tubing is 3/8" O.D. there is 13 FT (4 Meters) provided. Cut as needed for suction and discharge lines.

## 1.7 List of materials

✓ : standard

X: option available

	PVDF	PP	PPVO	PMMA	PVC	PE	CE	GLASS	PTFE	SS	FKM B	EPDM	WAX	SI
PUMP HEAD	✓	X								X				
DIAPHRAGM									✓					
BALLS							✓	X	X	X				
SUCTION HOSE	X				✓									
DELIVERY HOSE	✓				X									
VENTING HOSE	X				✓									
O RING									X		✓	X	X	X
LEVEL PROBE/ FOOT FILTER	✓													
LEVEL PROBE CABLE						✓								



DO NOT TRASH PACKAGING.  
IT CAN BE USED TO REPACKAGE THE PUMP.

## 2. PUMP'S DESCRIPTION

### 2.1 Control elements

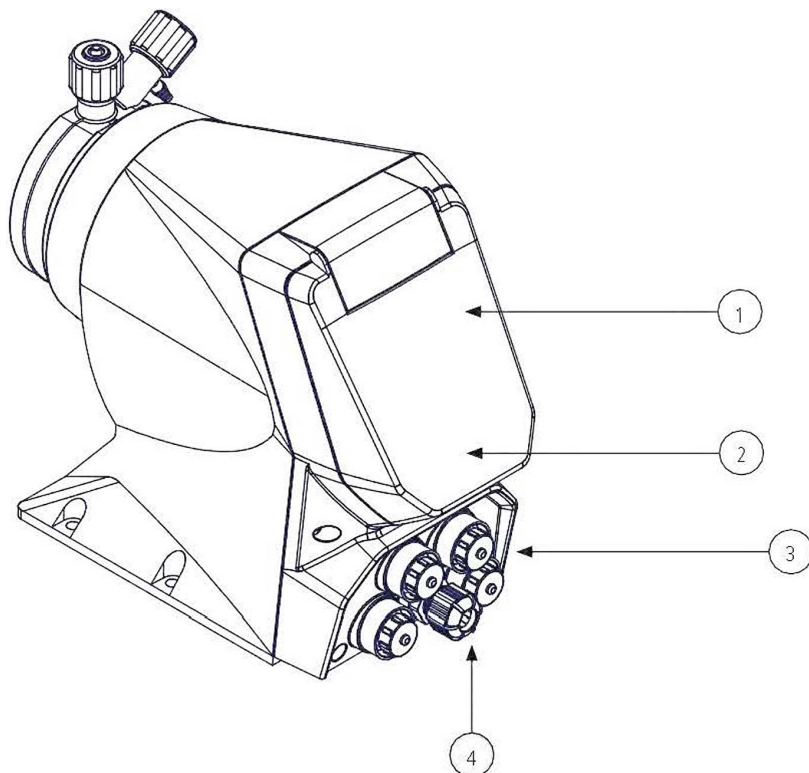

Control elements

No.	DESCRIPTION
1	Multicolor backlight display to indicate pump status: GREEN: pump running WHITE: stand-by YELLOW: warning condition RED: alarm condition
2	Multifunction rotary encoder
3	CONNECTORS: RS485 ALARM INPUT LEVEL
4	Main cable for power supply

## 2.1 Pump head

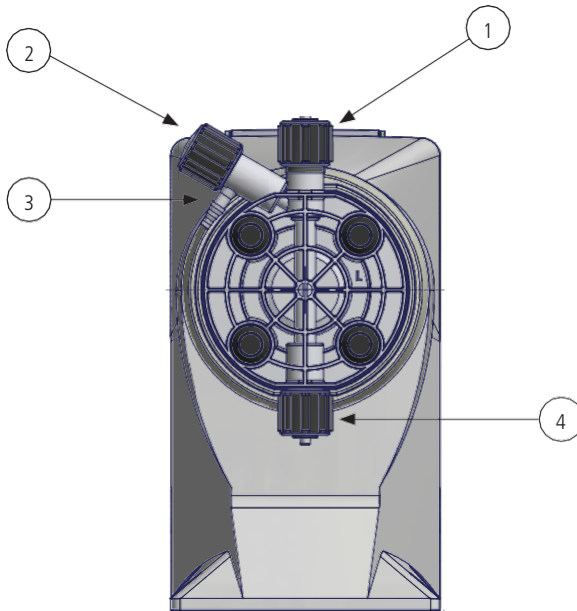

### Control elements

No.	DESCRIPTION
1	discharge connection
2	venting knob (not in Stainless Steel pump head)
3	venting connection (not in Stainless Steel pump head)
4	suction connection

## DIMENSIONS NEXTSTEP NS1, NS2, NS4

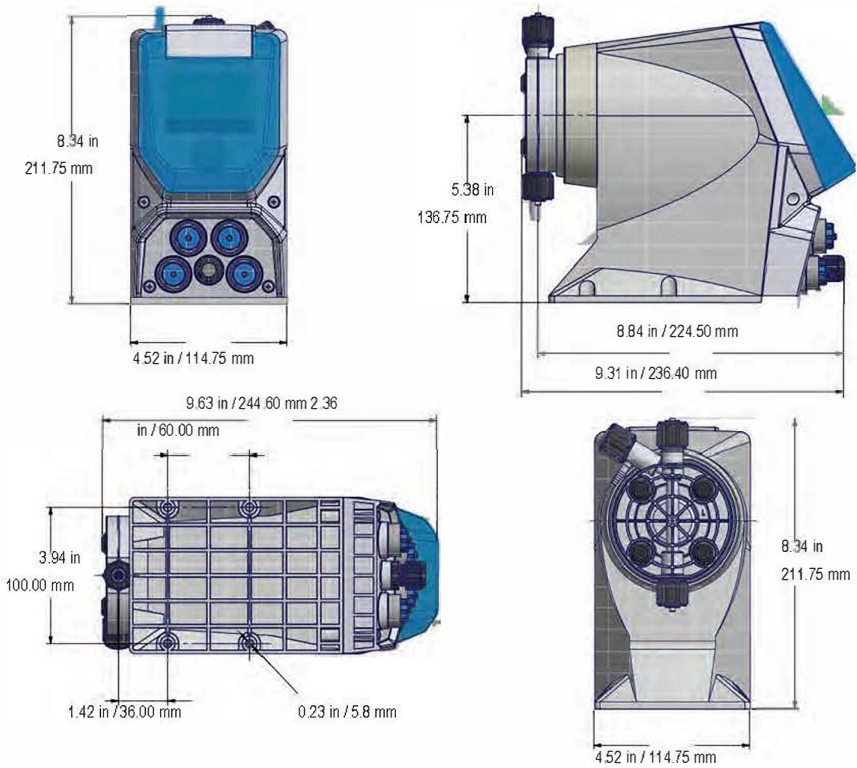

## DIMENSIONS NEXTSTEP NS3, NS5 thru NS9

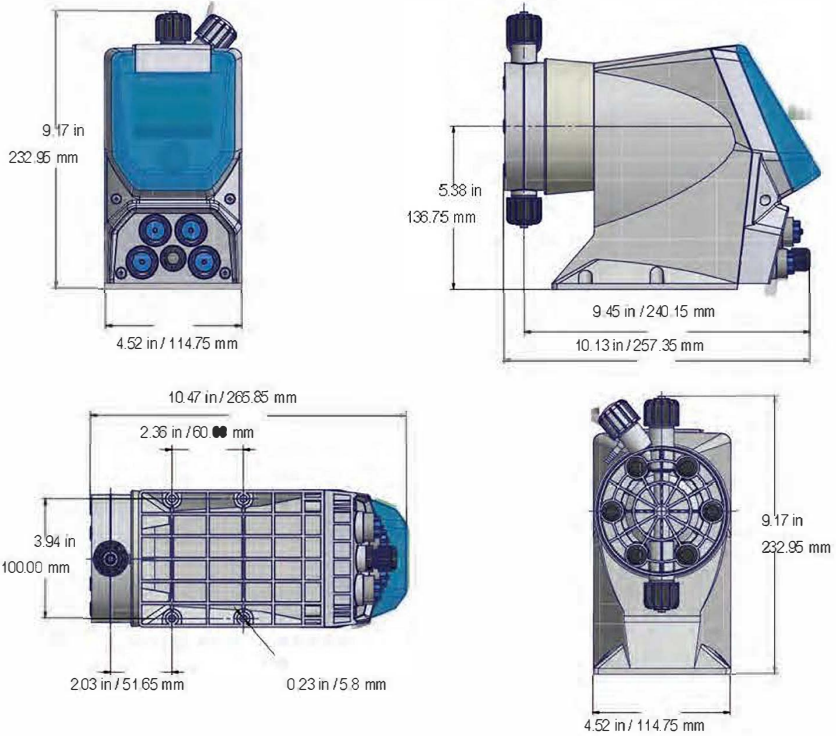

### 3. INSTALLATION

#### 3.1 How to install metering pump

5 steps to install and start-up the pump:

1. Choose a Pump location
2. Make system connections (hoses, level probe, injection valve)
3. Make electrical Wiring connections
4. Prime the Pump
5. Programming and start the pump

The operator must be aware of safety precautions to prevent improper product performance serious injuries, including death, damage to the equipment and/or property damage.

#### 3.2 User health and safety

**⚠ POWER SUPPLY DISCONNECTION**  
Disconnect power supply before you perform any installation or maintenance tasks. Failure to disconnect power may result in improper product performance, serious injuries, including death, damage to the equipment and/or property damage.

**⚠ SAFETY EQUIPMENT**  
Use safety equipment according to the company regulations. Use this safety equipment within the work area:

#### 3.3 The work area

**⚠ INSTALLATION AREA**  
Observe these regulations and warnings in the work area:

- Always keep the work area clean.
- Be aware of, and reduce, the risks presented by gas and vapors in the work area.
- Avoid all electrical dangers. Be aware of, and reduce, the risks of electric shock or arc flash hazards.
- Avoid water splashes and direct sun!

#### 3.4 Pump location

Pump must be installed on a stable support at a max 5ft (1,5 mt) height from tank's bottom.

**⚠ Injection point must be higher than tank to avoid accidental chemical injection.**

Otherwise, connect a **multifunction valve** on delivery pipeline.

**⚠ INSTALLATION PUMP GUIDELINES**

**Install the pump:**

- in a fixed location free of vibration.
- in an easily accessible place.
- in horizontal position.

**⚠ Only use materials compatible with product being pumped. Contact the chemical manufacturer for its resistance capacity to dosed product.**

#### 3.5 Requirements for product positioning

**⚠ REQUIREMENTS FOR PRODUCT POSITIONING**  
Only use fasteners of the proper size and material.  
Replace all corroded fasteners.  
Confirm all fasteners are properly tightened and that there are no missing fasteners.

3.6 Installation drawing

Fig. 4. Installation drawing

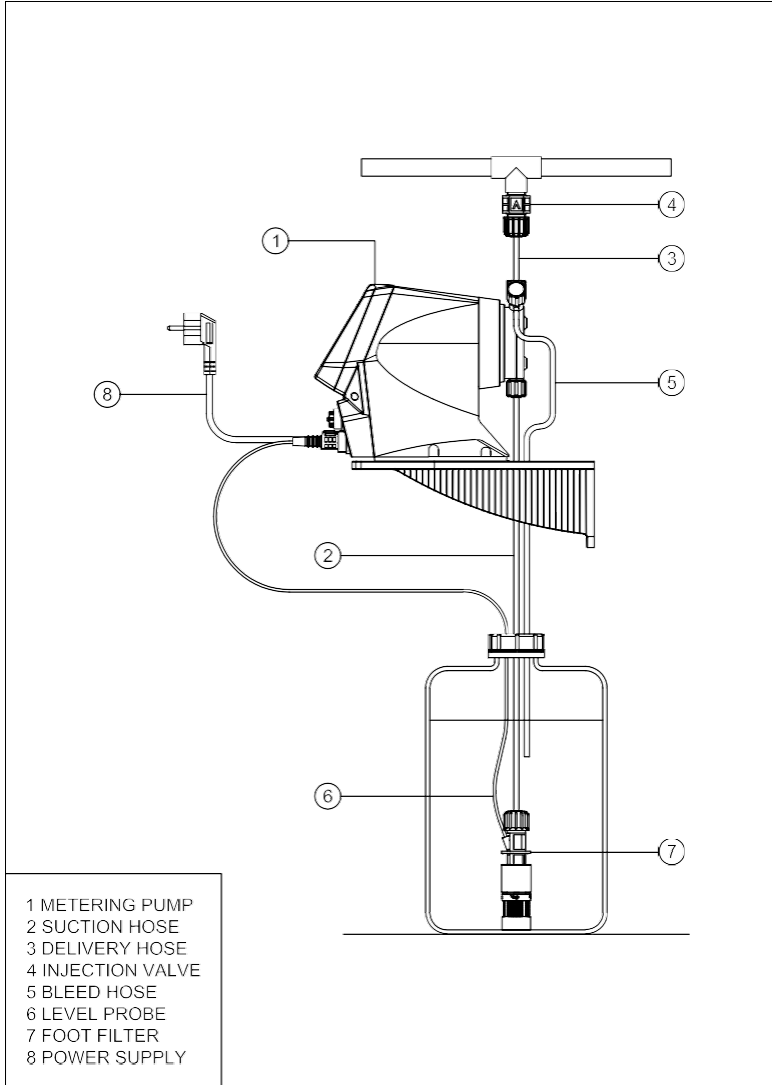

## 4. PIPING CONNECTIONS

### 4.1 Foot filter / Level probe

The level probe is assembled with a foot valve and strainer to filter sediments. Install the foot valve so that it hangs near the bottom of the tank in a vertical position.

**!** **Warning:** If there is a mixer installed in the tank, install a suction lance instead of level probe / foot valve.

Fig. 5. Level probe assembling diagram.

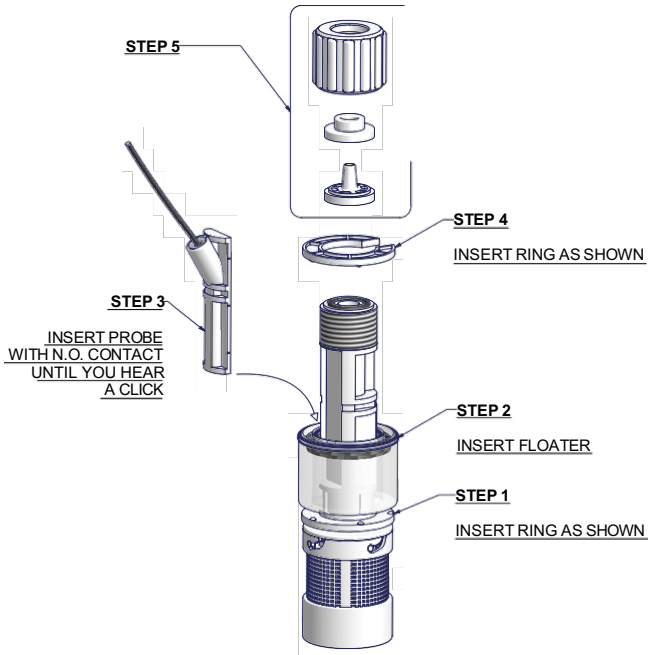

4.2 Suction hose connection

**⚠ Suction piping should be as short as possible and installed in vertical position to avoid air bubbles.**

**⚠ Hand-tighten the nuts firmly.**  
Do not use wrenches or any other tool.

Fig. 6. Suction hose assembling

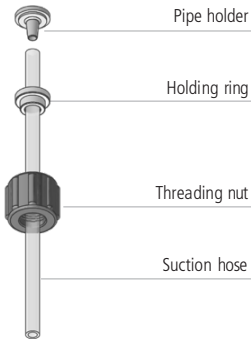

4.3 Pump head / Delivery hose assembling procedure

**⚠ Suction and discharge valves must be in the vertical position.**

**⚠ Discharge hose must be firmly fixed to avoid sudden movements that could damage nearby objects.**

**⚠ Hand-tighten the nuts firmly.**  
Do not use wrenches or any other tool.

Connect the other end of the hose to the injection valve

Fig. 7. Delivery hose / pump head assembling

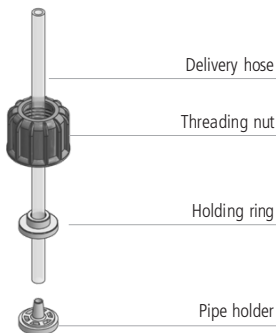

#### 4.4 Injection valve

Injection valve must be installed on plant.  
Injection valve will open at pressure greater than 4 psi.

#### 4.5 Venting hose

Insert one side of venting hose into discharge connector as shown in fig 8.

Insert other side of venting hose into the solution tank.  
During the priming procedure chemical will flow into tank.

Fig. 8. Manual venting pump head model (NOT STAINLESS-STEEL PUMP HEAD).

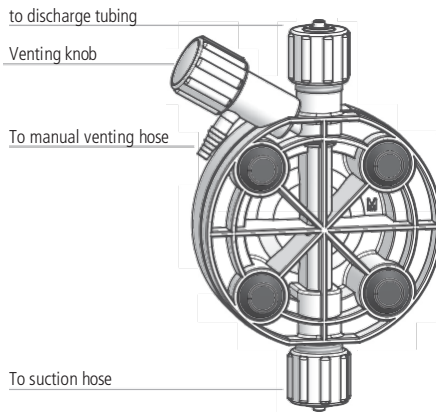

For priming procedure see **PRIMING**.

it's permitted to lightly bend venting hose.

**⚠** During calibration procedure ("TEST"), with a auto-purge pump head, insert venting hose into the graduated cylinder.

## 5. ELECTRICAL WIRINGS

### 5.1 Preliminary checks

**⚠ THE ELECTRICAL WIRING SHOULD BE CARRIED OUT BY AUTHORIZED AND QUALIFIED PERSONNEL ONLY IN ACCORDANCE WITH LOCAL REGULATIONS. FAILURE TO DO SO MANY RESULT IN SERIOUS INJURIES, INCLUDING DEATH, DAMAGE TO THE EQUIPMENT AND/OR PROPERTY DAMAGE**

Before to proceed, verify the following steps:

**1. Verify the data on rating plate.**

Confirm the electrical data on the rating plate corresponds to the electrical supply.

**⚠ Damage due to incorrect mains voltage!**

The dosing pump may be damaged if you connect it to the wrong mains voltage.

**2. Do not install the pump in parallel with heavy inductive loads (for example: motors).**

**3. Verify peak Amps. Pumps do not use motor overload protection.**

## 6. CONNECTIONS

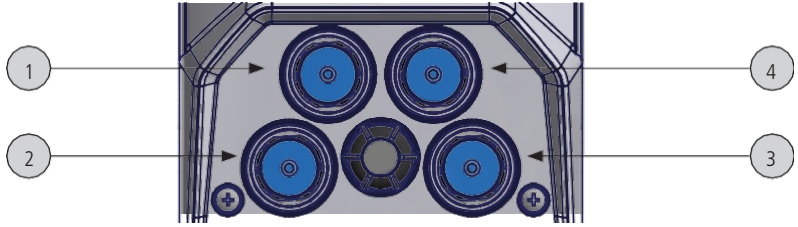

No.		Description	Cable Color	Assignments
1	 5 poles connector version	RS485 MODBUS	1 Green	- RS485
			2 White	+ RS485
			3 Brown	GND
		mA	4 Blue	+mA
			5 Yellow	-mA

No.	M12x1	Description	Cable Color	Assignments
1		RS485 or MODBUS (option)	1 Yellow	+ RS485
			2 Green	-RS485
			3 Blue	gnd

1		mA Output (option) see page 35	1 Yellow	mA Output (Signal)
			3 Blue	gnd

No.		Description	Cable Color	Assignments
2		STAND-BY	4 White	+ stand-by
			3 Brown	- gnd
		INPUT <sup>1</sup>	2 Blue	+ input (Max 120hz freq.)
			3 Brown	- gnd
		EXT CONSTANT	1 [Yellow] - if pulse sender water meter with Hall effect	+ 12 V
			5 Green	+ Ext const
			3 Brown	- gnd

<sup>1</sup> This input may be used as:

- pulse sender water meter
- pulse sender water meter with Hall effect
- startup contact for "BATCH" mode
- voltage input for "VOLT" mode
- current input for "mA" mode
- pulse input

No.		Description	Cable	Assignments
3		LEVEL	to probe level (1 yellow, 2 blue)	/

No.		Description	Cable Color	Assignments
4		ALARM dry contact	3 White	n.o.
			1 Yellow	n.c.
			2 Green	common

## 7. START UP

### 7.1 Start up

**All operations previously described must be carried out before starting the pump.**

1. Pump location
2. Piping connection
3. Connections (power supply, stand-by/input, level, alarm output)
4. Set up



**The pump could take up few seconds before start. It takes time for the motor to ramp up to full speed.**



**Control the pressure to correspond to the pressure rating on the nameplate**

If the pump does not start to dose:

- a) Stop the pump.
- b) Prime the pump head.
- c) Start the pump again.

### 7.2 Test

**Use the TEST function to determine the pump flow rate with the liquid used.**





1. Install the pump and insert the suction tube (complete with the foot valve) into a graduated cylinder. For NextStep pumps up to 2 GPH (7.5 l / h), a 250 ml graduated cylinder is recommended.
2. Put the product to be dosed into the graduated cylinder, prime the pump making sure that the pump head is full of product. Check the initial quantity of the product present in the graduated cylinder including the foot valve.
3. Power up the pump.
4. From the settings/more menu select "TEST" and enter the duration of the test.
5. Press on the "START" icon. The pump will begin to dose the liquid, at the pressure of the system.
6. At the end of the test, read the remaining quantity of chemical on the graduated scale. The dosed quantity will be: the initial quantity minus the remaining quantity.

The capacity of the pump is obtained by multiplying the dosed quantity/min x 60 minutes.

E.g. : Dosed value: 500ml. Test duration time: 60 seconds.  
Hourly flow rate of the pump  $500 \times 60 = 30.000 \text{ ml/h} = 30 \text{ l/h}$

## 8. PRIMING

### 8.1 Precautions

-  **Pump should be interlocked with a no-flow protected device to automatically shut-off the pumps when there is no flow**
-  **Take measures necessary shall be taken to prevent cross contamination of chemicals!**
-  **Chemical feeding must be stopped during backwash cycles and periods of no flow as these conditions may introduce the potential for chemical overdosing. Not doing so may result in elevated chemical concentrations and hazardous gas introduction into the pool or spa.**
-  **Never operate any pumping system with a blocked suction and discharge. You must take all necessary measures to avoid this condition.**
-  **SAFETY EQUIPMENT**  
**Use safety equipment according to the company regulations. Use this safety equipment within the work area:**
  - **Helmet**
  - **Safety goggles (with side shields)**
  - **Protective shoes**
  - **Protective gloves**
  - **Gas mask**

### 8.2 Priming

To prime the pump:



1. perform al piping (delivery, suction and venting hose); open priming knob
2. choose PRIMING icon on main menu. It could take few seconds before pump starts count down
3. When the chemical starts to flow into discharge hose, close discharge knob.
4. Proceed to standard operating condition.

For viscous liquids, to facilitate priming: insert a 20 cc syringe on venting pipe and suck; When syringe is almost full close the discharge valve turning the knob.

## 9. SET UP

### 9.1 Basic operations









Main adjustment on encoder

Choose a menu	Rotate encoder on the menu items.
Enter into the menu	Press encoder on the menu item, the display will show the options available.
Confirm a selection, save and go back to main screen	Press encoder on  icon
Confirm a selection, save and go back to main menu	Press encoder on icon 
Enter a value (numeric)	Press encoder on the value, rotate clockwise to increase, counterclockwise to decrease. Press to choose.

To save changes press SAVE icon.

Each programming screen has an automatic timeout after 60 seconds, then the HOME screen will be displayed and the pump resumes normal operation. Choose the desired language on initial power up. The Language can be changed in the Setting/More Menu.

### 9.2 Display icons

 PRIMING	 STOP
 STATISTICS	 RESET
 SETTINGS	 SAVE / MAIN SCREEN
 OFF	 ALARM ALERT / STAND-BY
 SAVE / BACK	 DELIVERY SPEED
 START	 SLOW MODE
 INFO	

#### 9.2.1 Quick mode for frequency adjustment

From main screen, wait until the cursor on the icons disappears. Press the encoder for about 5 seconds and adjust the pump capacity in constant mode. In other working modes this feature takes you directly to the settings screen for the working mode the pump is set to.

### 9.3 Menu overview

HOME

WORKING  
MODE

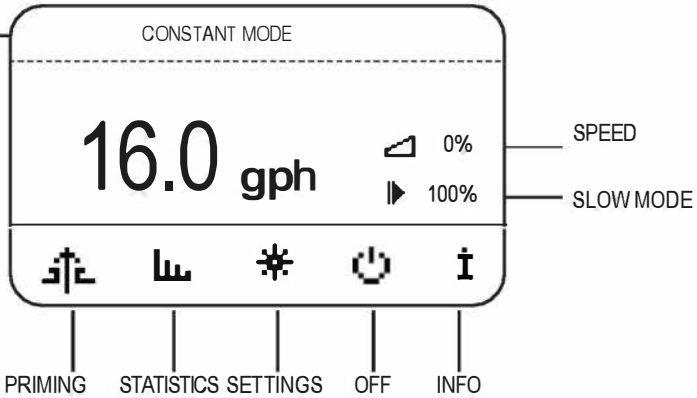

\* From the menu Settings>More>View the display can be changed between "%" as the main unit and "g/h" or "l/h" as the main unit and "%" or "%%" only.

 PRIMING

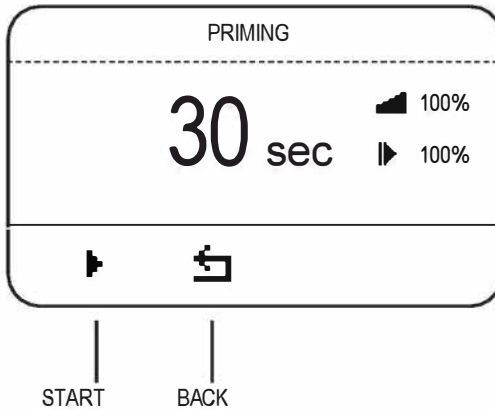

START: to run the PRIMING.

■ Stop button will stop and reset the counter (default value 30 sec).

The pump could wait up to few seconds before starts PRIMING.

**Note on the user password: to change working settings and a USER password has been created (def.. "0000"). From main menu rotate the encoder counter-clockwise and when no icon is selected press and hold the encoder (~10 seconds) until the user password request appears.**



## STATISTICS

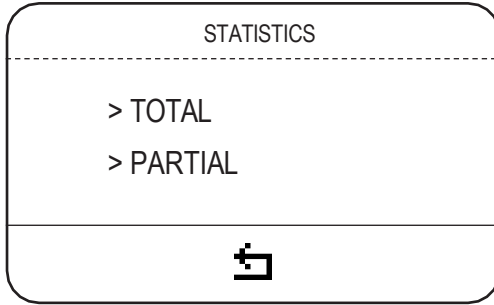

> TOTAL

> PARTIAL

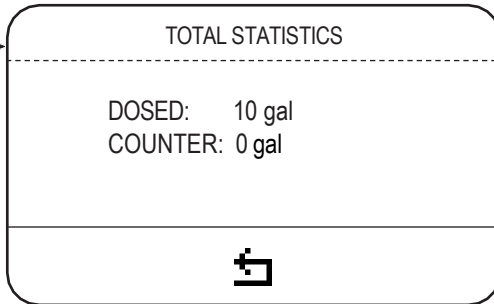

DOSED: total quantity dosed (max 999.999.999 L).  
COUNTER: water meter counter.

To reset all counters, see LOAD DEFAULT menu:  
SETTINGS / MORE / LOAD DEFAULT.

> TOTAL

> PARTIAL

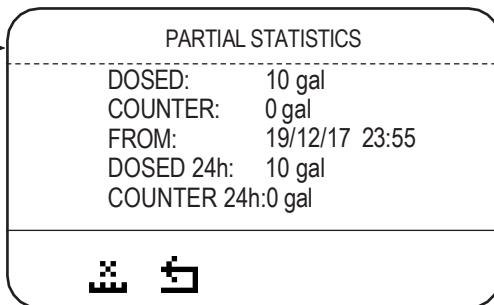

RESET

DOSED: total quantity dosed (max 999.999.999). COUNTER: water meter counter.  
FROM: date and hour of last statistic reset.  
DOSED 24h: quantity dosed yesterday (00:00 to 23.59 of yesterday).  
COUNTER 24h: water meter counter (00:00 to 23.59 of yesterday).  
To reset counters press RESET icon.



## SETTINGS

Setting session have an automatic timeout after 60 seconds, then go back to HOME screen.

### SETTINGS

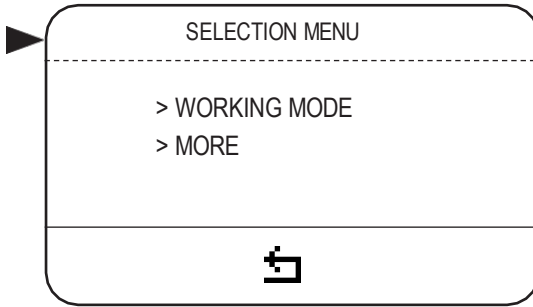

#### SETTINGS MENU

Use this menu to set working mode and to define all settings.

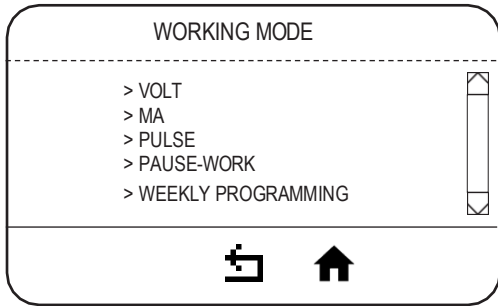
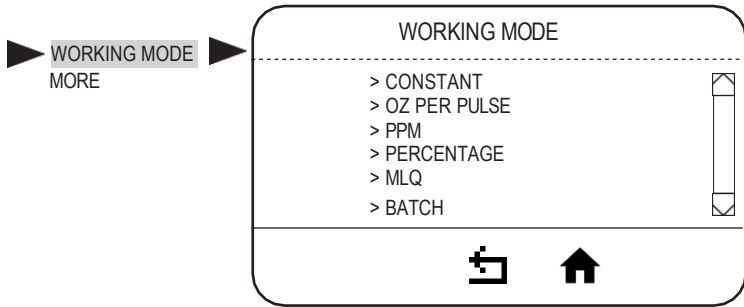

**Note: only the PERCENTAGE – PPM – CC-PULSE - MLQ - modes affect pulse sender water meter stats.**

MODE	PARAMETERS TO SET*		NOTE	WHEN
<b>CONSTANT</b>	GAL/h: GALLONS / HOUR. TURN THE KNOB TO THE REQUIRED GALLONS PER HOUR VALUE. THE PUMP WILL INCREASE / DECREASE THE SPEED ACCORDING TO ITS MAXIMUM CAPACITY.		The pump doses at a constant flow rate corresponding to a specific number of motor rotations. The current flow rate as a function of capacity can be visualized by the  icon and percentage next to it.	Use this mode to dose a constant rate of chemical up to the capacity of the pump.
<b>OZ PER PULSE<sup>4</sup></b>	OZ MIN 0,0001 OZ 1 PULSE = OZ SET	MAX OZ 2X	Dosing rate is determined by pulses from WM (or other pulse sender) and "timeout" setting in More → Timeout menu.	Use this mode to dose a specific amount (measured in OZs) within the "timeout" period after each pulse from a WMr (or other pulse sending device)
<b>PPM<sup>3</sup></b>	PPM: 0.1 up to 9999.99 CONCENTRATION: 0.1 to 100%		Dosing rate is determined by pulses from a water meter (or other pulse sender), PPM, chemical (%) concentration and the "timeout" setting in More → Timeout menu.	Use this mode to maintain a specific ppm (parts per million) of chemical to process fluid.
<b>PERCENTAGE<sup>3</sup></b>	PERCENTAGE: 0.01% to 100.00 CONCENTRATION: 0.1% to 100%		Dosing rate is determined by pulses from a water meter (or other pulse sender), percentage (%), chemical concentration and the "timeout" setting in More → Timeout menu.	Use this mode to maintain a specific percentage of chemical to process fluid.
<b>MLQ<sup>3</sup></b>	MLQ: 0.01 up to 1000.00 CONCENTRATION: 0.1% to 100%		Dosing rate is determined by pulses from a water meter (or other pulse sender) on the base of set MLQ (milliliters per quintal), chemical product concentration (%) and the "timeout" setting in More → Timeout menu.	Use this mode to maintain a specific mL/ quintal concentration of chemical.
<b>BATCH</b>	EXTERNAL MANUAL	EXTERNAL Up to 100.000 Gal Up to 100.00 liters Contact: N.C. (or N.O.)	External mode: signal from an external contact starts the pump to dose the amount product at max flow rate.	Use this mode to dose a specific amount of chemical based on an external contact signal
		MANUAL Up to 100.000 Gal Up to 100.00 liters (Start icon for manual dosing)	Manual mode: to dose a quantity at max flow rate (manual start).	Use it to dose a specific amount of chemical based on pressing button on the pump.
<b>VOLT</b>	HIGH: 10.0 V H LOW: 0.0 V	Up to 21.965 GPH Up to 83.146 LPH	In Voltage mode, the pump doses proportionally between the low and high voltage values. In VOLT working mode, voltage input value is shown on main menu (top/right).	Use this mode to dose chemical at a rate that is linearly scaled to the voltage range selected

\*Only one mode can be set at a time.

<b>MA</b>	HIGH: 20.0mA LOW: 0.0 mA	Up to 21.965 GPH Up to 83.146 LPH	In mA mode, the pump doses proportionally between the low and high mA values. In mA working mode, mA input value is shown on main menu (top/right).	Use this mode to dose chemical at a rate that is linearly scaled to the current range selected.
<b>PULSE</b>	HIGH: Up to 7200 p/m LOW: 0 p/m	Up to 21.965 GPH Up to 83.146 LPH	The pump doses proportionally between the low and high p/m values. In Pulse working mode, pulses number is shown on main menu (top/right).	Use this mode to dose chemical at a rate that is linearly scaled to the frequency of the input pulses.
<b>PAUSE-WORK</b>	WORKING: 060 min (max 900) PAUSE: 060 min (max 900) Up to 21.965 GPH Up to 83.146 LPH	 15%	<ul style="list-style-type: none"> <li>•Pump doses the set quantity during working time.</li> <li>•Pause-work cycle repeats regularly.</li> <li>•Pause-work cycle starts with the working.</li> <li>•On Home Screen the amount being dosed will be displayed on the counter (top/right) during working session.</li> <li>•If settings are incongruent (i.e.: quantity to dose in 60 min is over pump capacity), values are set automatically on max capacity at max flow rate.</li> <li>•% of capacity is based on pump capacity set.</li> </ul>	Use this mode to dose the set quantity of chemical during the amount of time set and then to pause pumping for the amount of time set.
<b>WEEKLY PROGRAMMING</b>	<input checked="" type="checkbox"/> PROGRAM 1 <input type="checkbox"/> ... <input type="checkbox"/> PROGRAM 24	Start: hh:mm Duration: 00h 00m Quantity: 2.5 G <input checked="" type="checkbox"/> Sunday <input type="checkbox"/> Monday <input type="checkbox"/> ... <input checked="" type="checkbox"/> Saturday	<ul style="list-style-type: none"> <li>•Set programs (up to 24).</li> <li>•For each program set start time, duration, quantity to dose and days.</li> <li>•Pump will dose the quantity starting at the time set. The duration cannot be past midnight of the same day.</li> <li>•Minimum quantity is calculated basing on pump capacity.</li> <li>•Do not overlap programs.</li> </ul>	Use this mode to set up to 24 individual/ separate weekly pump programs

“NOTE:

- (1) Only one mode can be set at a time.
- (2) All flow rates in L/h can also be set to Gal/h using the Unit of Measure option under “MORE”
- (3) “UPKEEP” functionality. The “PPM”, “Percent” and “MLQ” work modes have an additional configurable functionality called “upkeep” which can be enabled or disabled. This function allows to set a “timeout”, countdown between 0 and 24hours, after which if the pump has not yet received a pulse from the pulse-sender water meter, it performs a series of maintenance dosages until the value in ml/h set in the “upkeep dosage” field is finished. “
- (4)“OZ SET”. Maximum value that can be set is 90% of the pump capacity setting in gallons per hour divided by 10,800 (rpm).

▶ WORKING MODE  
MORE ▶

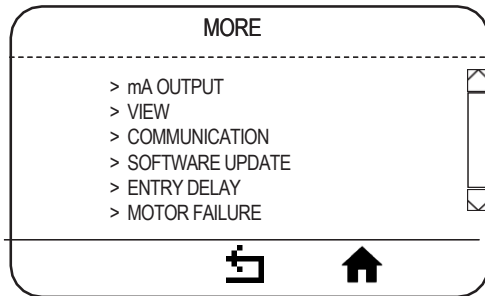
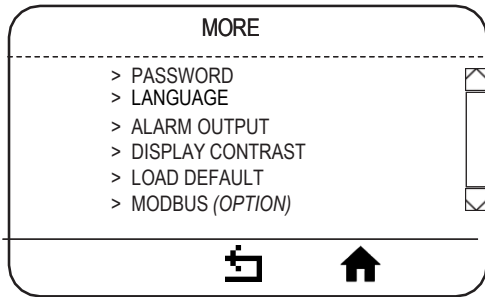
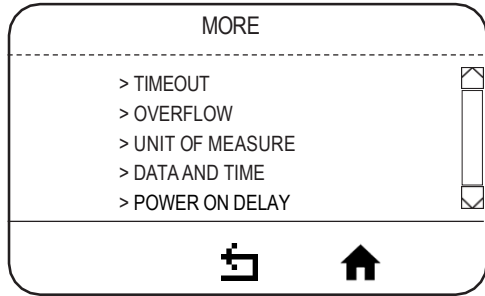
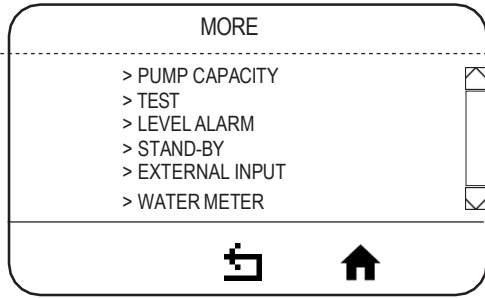

	PARAMETERS TO SET		NOTE
<b>PUMP CAPACITY</b>	FLOW 99 L/h, 26.15 gph CC/MIN: 1650.00 SLOW MODE: 100%		<ul style="list-style-type: none"> <li>•This setting is for setting the pumps Maximum Capacity. This setting SHOULD NOT be used to change the current flow rate of the pump.</li> <li>•Maximum flow rates will be adjusted automatically based on the slow mode setting.</li> <li>•Maximum pump capacity default setting is based on pump's label.</li> <li>•Slow mode enables reduction of the suction speed. It can be set from 30% to 100%</li> </ul>
<b>TEST</b>	UP TO 60 MINUTES (DEFAULT 6 MINUTES)		Run the test to verify pump capacity (max flow rate/speed).
<b>LEVEL ALARM</b>	STOP AFTER: UP TO 378 liters or 100 gallons CONTACT: N.O.		<ul style="list-style-type: none"> <li>•The level alarm is an alarm on tank fluid level. The alarm will activate (turn the screen red and stop pumping) once the float sensor is tripped and the amount of chemical set here is pumped. To clear alarm, fill the tank to the point where the float sensor is no longer tripped..</li> <li>•Level alarm set to 0 stops the pump immediately upon level sensor tripping.</li> <li>•Can be set to N.O. or N.C contacts.</li> </ul>
<b>STAND-BY</b>	DISABLED <input type="checkbox"/> STAND-BY <input checked="" type="checkbox"/>	CONTACT: N.O.	Enabling this setting allows the use of an external contact switch input to remotely start and stop the pump. External contact switch can be set to N.O. or N.C.
<b>EXTERNAL INPUT</b>	DISABLED <input type="checkbox"/> EXTERNAL INPUT <input checked="" type="checkbox"/>	CONTACT: N.O. UP TO 98.9 LPH, 26.15 GPH  15%	<ul style="list-style-type: none"> <li>•This enables the External Constant Input. When the external contact is switched it continuously pumps at the flow rate set here.</li> <li>•Can be set to N.O. or N.C.</li> <li>•The External Constant signal will interrupt any currently running operating mode.</li> </ul>
<b>WATER METER</b>	L/pulse: 1.0 <input checked="" type="checkbox"/> 0.1 to 1200 [gal/pulse: 1.0] <input type="checkbox"/> 0.1 to 371 pulse/L: 1.0 <input type="checkbox"/> 0.1 to 1200 [pulse/gal: 1.0] <input type="checkbox"/> 0.1 to 4542.0		<ul style="list-style-type: none"> <li>•This option allows the user to set what kind of water meter is attached to the pump.</li> <li>•Settings for defining the meter as Liters/Pulse or Pulses/Liter.</li> <li>•This contributes to determining the dosing rate in PPM, MLQ and PERCENTAGE working modes.</li> </ul>
<b>TIMEOUT</b>	1 - 999 SEC Default = 10 sec.		This is the amount of time the pump will take to dose in response to a pulse input in CC/pulse, PPM, MLQ, Batch, Pulse and Percentage working modes
<b>OVERFLOW</b>	ALARM WORK  ALARM STOP		<ul style="list-style-type: none"> <li>•OVERFLOW displays an alarm on the main screen that can be set to stop the pump.</li> <li>•Overflow can occur in PPM, PERCENTAGE, MLQ or BATCH working modes.</li> <li>•In PPM, PERCENTAGE or MLQ mode, overflow alarm occurs when dosing rate exceeds pump capacity.</li> <li>•In BATCH mode overflow alarm occurs when pump receives an external signal during dosing.</li> </ul>
<b>UNITS</b>	LITRES	GALLONS	

<b>DATA &amp; CLOCK</b>	Format: dd/mm/yy 24 Date: Saturday 26/12/15 time: 04:01:19	Format: mm/dd/yy 12 Date: Saturday 12/26/15 time: 04:01:19 am	<ul style="list-style-type: none"> <li>•Date and Time Format can be changed as well as the actual time and date.</li> <li>•Changing Data &amp; Clock, partial statistics will be reset.</li> </ul>
<b>POWER ON DELAY</b>	00 to 10 min		This setting allows the user to set the amount of time it takes for the pump to turn on after it is powered up.
<b>PASSWORD</b>	ADMINISTRATOR PASSWORD New password: 0 _ _ _	> ADMINISTRATOR > USER	<ul style="list-style-type: none"> <li>•Default is no password.</li> <li>•Insert password: the first time you set administrator password.</li> <li>•Once administrator password is set, you can set a user password. Exit from this menu and enter again to set the user password.</li> <li>•Reset password with LOAD DEFAULT.</li> </ul>
<b>LANGUAGE</b>	IT - EN - FR - DE - ES - PT - RU		Choose language
<b>ALARM OUTPUT</b>	ENABLED CONTACT N.C. OR (N.O.) LEVEL WARNING LEVEL ALARM STANDBY OVERFLOW WARNING OVERFLOW ALARM NO INPUT HIGH TEMPERATURE HALL SENSOR WARNING HALL SENSOR ALARM		<ul style="list-style-type: none"> <li>•ALARM OUTPUT can be enabled or disabled and set to n.o or n.c.</li> <li>•LEVEL – level sensor will trigger a warning or an alarm or both</li> <li>•STANDBY – Alarm will be triggered when pump is in standby mode</li> <li>•OVERFLOW – Alarm, warning or both will be triggered by an over flow condition in PPM, PERCENTAGE, MLQ or BATCH working modes.</li> <li>•NO INPUT – Alerts user that the voltage or current loop inputs are open (i.e. not connected).</li> <li>•HALL SENSOR – Internal Hall Effect Sensor does not detect motor turning.</li> </ul>
<b>DISPLAY CONTRAST</b>			Allows the user to change the display contrast to increase display readability.
<b>LOAD DEFAULT</b>	YES	NO	Factory Reset

<b>MODBUS (if requested)</b>	ID: 1 BAUDRATE: 9600 FORMAT 8N1 (default)	Set the ID (1 to 255). Set the communication speed: 2400/4800/9600 /19200/38400/115200. Set the format.
------------------------------	---	---

<b>ENTRY DELAY</b>	Delay (seconds) before the pump acquires digital signal from Standby or Level. Default value is suitable in the most of cases.	Select proper delay according to input signals.
--------------------	--	---

#### 9.4 Pump capacity setting

**Pump capacity default setting is based on pump's label.**

Values set in PUMP CAPACITY menu (SETTING / PUMP CAPACITY) are affecting pump working mode. NOTE: The pump could take up few seconds before starts any operation (PRIMING, run TEST, etc.).

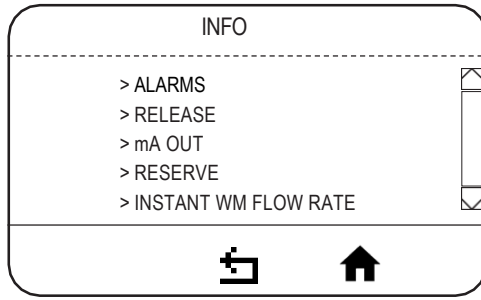

Icon  on main menu indicates one or more alarms active or stand-by.

Tab. 1. Alarms management

ALARM	PROBLEM	HOW MANAGE
LEVEL	No product	Refill the tank
OVER FLOW	Requested capacity by water meter exceeds maximum pump capacity	Check settings Check pump capacity Set pump OFF then ON.

Tab. 2. Release

<b>Release</b>	The pump software release version
<b>mA OUT</b>	Current output from pump

Tab. 3. Reserve

<b>Reserve</b>	The reserve of product to be dosed as set in the level alarm menu (stop after))

Tab. 4. Instant WM Flow Rate

<b>Instant</b>	The gallons per hour or liters per hour that have passed through the pulse sending water meter

## 10. ELECTRICAL WIRING

### 10.1 Preliminary checks



The electrical wirings should be carried out by **AUTHORIZED AND QUALIFIED PERSONNEL** only in accordance with local regulations.

Before to proceed, verify the following steps:

- 1. Verify the data on nameplate.**  
Make sure that the electrical data on the nameplate corresponds to the electrical supply.
- 2. Verify the grounded power outlet.**  
The pump must be plugged to a grounded power outlet.
- 3. Verify the cable.**  
Cable type and cross-section must be in accordance to pump data.

### 10.2 mA OUTPUT MODE

mA OUTPUT (setup menu)	DISABLED <input type="radio"/>	- Option is disabled
	SAME AS INPUT <input type="radio"/>	- mA output values are the same as INPUT
	FLOW FUNCTION > <input type="radio"/>	- Click to enter into the following menu: HIGH: 21.9 GPH or 83 L/H 20.0 mA LOW: 0.0 GPH or L/H 0.0 mA Set values according to required output (0-20mA). Note: HIGH value must be higher than LOW value

### mA OUTPUT CALIBRATION and VOLTAGE CALIBRATION (ALREADY FACTORY CALIBRATED - NOT REQUIRED)

If it is necessary to calibrate the mA output follow these steps: while the NEXSTEP logo is displayed, press and hold the encoder until the screen below appears. Move the cursor on Duty Cycle 4mA, connect the multimeter to the OUTPUT mA and rotate the encoder (percentage value) until the multi meter displays 4mA. Repeat the operation also for 20mA. Press the HOME key to confirm the procedure. Voltage shown on screen indicates that pump is ready to calibrate voltage input. Based on given input voltage set the required value then press HOME key to confirm.

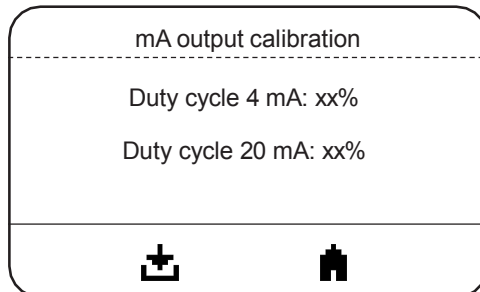

## 11. MAINTENANCE

### 11.1 Maintenance schedule

**⚠** Check the equipment at least once a month to confirm that the requirements of potable drinking water treatment and the maintenance requirements as declared by the manufacturer are met.

#### **⚠** OPERATOR PROTECTION

Use safety equipment according to local regulations.

Use this safety equipment within the work area during installation, service and when handling chemicals:

- protective mask
- protective gloves
- safety goggles
- ear plugs or hear muffs
- further security device, if necessary.

**⚠** **POWER SUPPLY DISCONNECTION** Always disconnect power before performing any installation or maintenance tasks. Failure to disconnect power may result in improper product performance, serious injuries, including death, damage to the equipment and/or property damage.

**i** Installation and maintenance tasks should be carried out by **AUTHORIZED AND QUALIFIED PERSONNEL** only in accordance with local regulations.

---

Use OEM spare parts.

**⚠** **Shutdown the dosing pump before any maintenance operation**  **Shutdown procedure.**

A maintenance schedule includes these types of inspections:

- Routine maintenance and inspections
- Three-month inspections
- Annual inspections

Shorten the inspection intervals appropriately if the pumped chemical is abrasive or corrosive.

#### **Routine maintenance and inspections**

Routine maintenance must include the following steps:

- Inspect the seal. Ensure that there are no leaks from the mechanical seal.
- Check electrical wiring
- Check for unusual noise and vibration.
- Check the pump and piping for leaks.
- Check for corrosion on parts of the pump and / or on hoses.

#### **Three-month inspections**

Perform these tasks every three months:

- Check for tightening.
- Check the mechanical seal if the pump has been left idle.

#### **Annual inspections**

Perform these inspections one time each year:

- Check the pump capacity (as per nameplate).
- Check the pump pressure (as per nameplate).
- Check the pump power (as per nameplate).

### 11.2 Maintenance inspection

If the pump performance does not satisfy your process requirements, and the process requirements have not changed, then perform these steps:

1. Disassemble the pump.
2. Inspect it.
3. Replace worn parts.

---

### 11.3 Shutdown procedure

 **This procedure SHOULD BE CARRIED OUT BY AUTHORIZED AND QUALIFIED PERSONNEL**

 **OPERATOR PROTECTION**

Use safety equipment according to the company regulations.

Use this safety equipment within the work area during installation, service and when handling chemicals:

- protective mask
- protective gloves
- safety goggles
- ear plugs or hear muffs
- further security device, if necessary.

Shutdown the dosing pump **before any maintenance operation** or **before long downtimes**. Disconnect power and ensure it cannot be restarted.

 **Depressurize the system.**

Drain the chemical from pump head.

Release the pressure and disconnect the discharge pipe from the discharge valve.

Rinse the pump head and clean all valves.

---

### 11.4 Display battery replacement procedure

 **POWER SUPPLY DISCONNECTION**  
**Always disconnect power before you replace the battery . Failure to disconnect power may result in improper product performance, serious injuries, including death, damage to the equipment and/or property damage .**

 **This procedure should be carried out by AUTHORIZED AND QUALIFIED PERSONNEL only in accordance with local regulations.**

- Disconnect power supply.
- Unscrew the 4 screws under the pump and remove the base.
- Locate the battery slot behind display.
- With a screwdriver push the battery out of its slot.
- Replace with a new one (CR2032 - 3V) respecting polarity (+/-) as shown on the slot.
- Close the base with the 4 screws.

## 12. TROUBLESHOOTING

Tab. 6. Guide to troubleshooting.

PROBLEM	CAUSE	REMEDY
Dosing pump not delivering or output too low	Suction valve leaking or blocked	Clean or replace suction valve
	Suction pipe leaking or blocked	Replace suction pipe
	Air bubbles into pump head or into suction pipe	Prime the pump as described in "Priming"
	Viscosity too high	Increase the pipe diameter or contact manufacturer
	Suction lift too high	Decrease lift
	Foot filter obstruction	Clean the foot filter
Motor and pump head too hot	Wrong wiring or defecting contact	Check wiring
	Pressure too high	Install a valve
	Delivery pipe obstructed or blocked	Clean delivery pipe
Liquid loss	Diaphragm rupture	Contact manufacturer for diaphragm replacement
Display is illuminated but no text appears	Display battery low	Replace display battery. Display battery is located on the circuit board under the display.

If the problem cannot be solved please contact after-sales service

**i** Before return the dosing pump to the manufacturer Repair service, drain the chemical from pump head and rinse it.

### 13. FLOW CURVES

Flow rate indicated is for H<sub>2</sub>O at 20°C at the rated pressure. Dosing accuracy  $\pm 1\%$  at rated pressure.

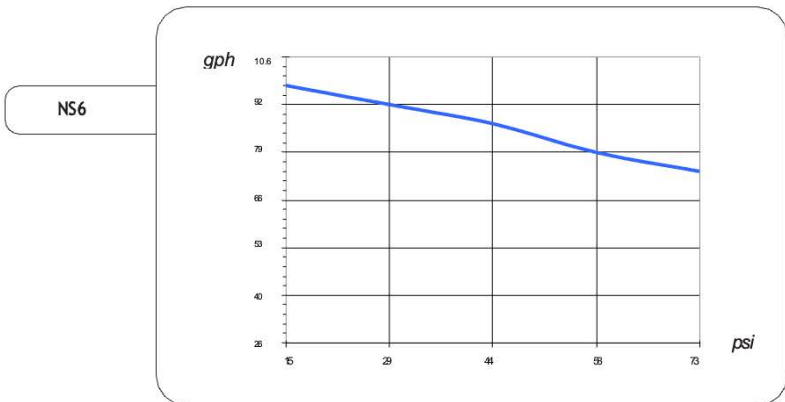
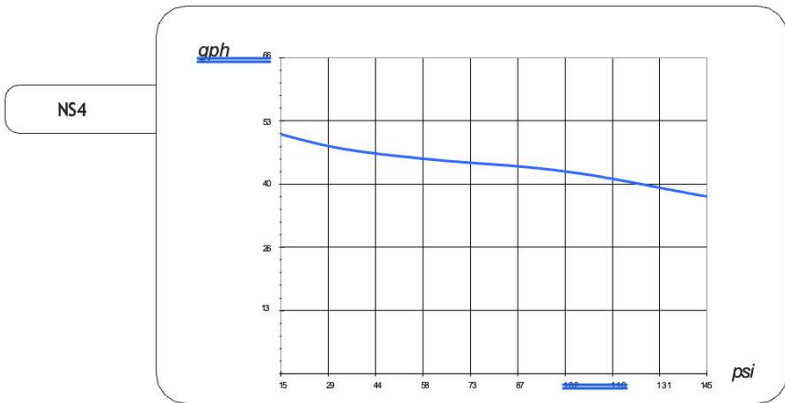
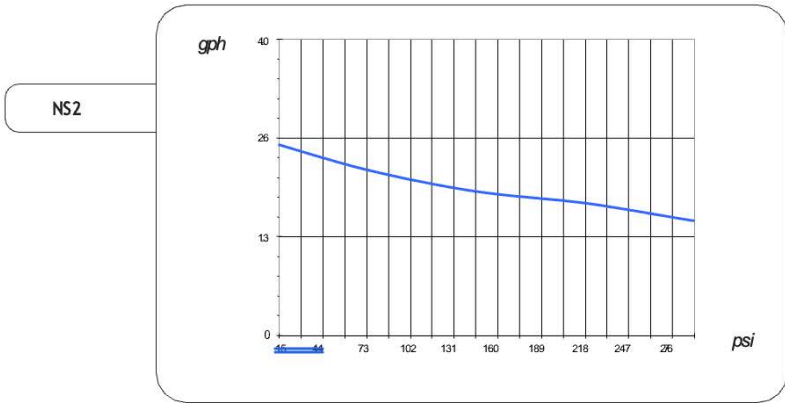

### 13. FLOW CURVES

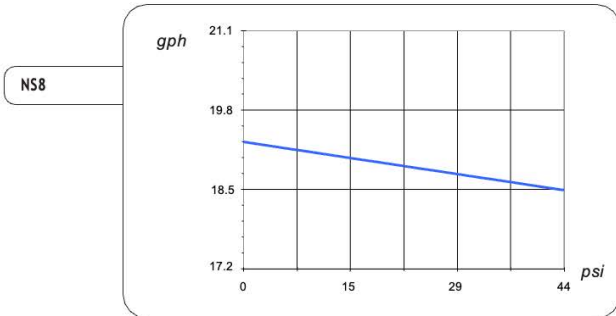
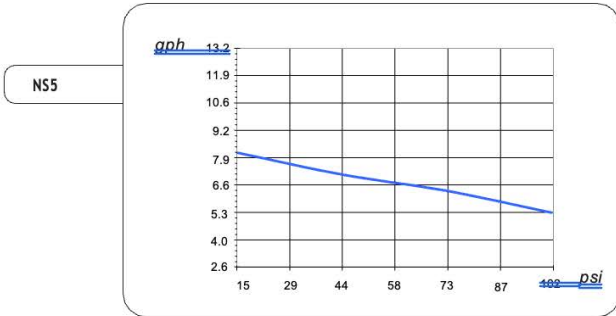
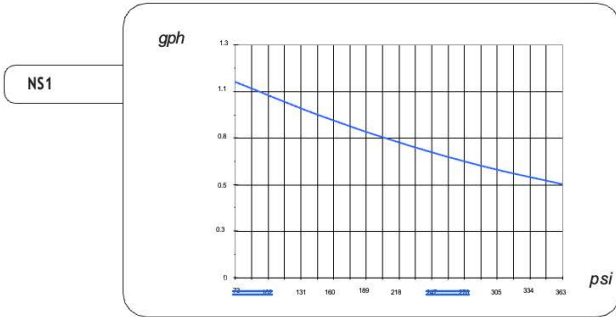
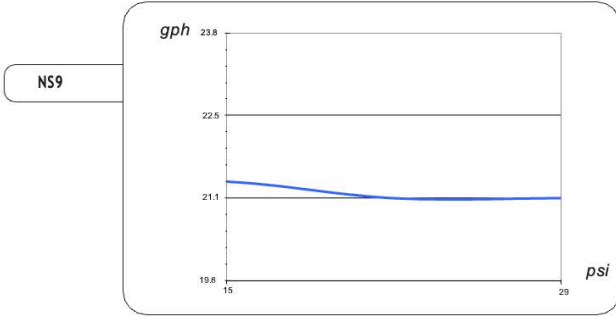

### 13. FLOW CURVES

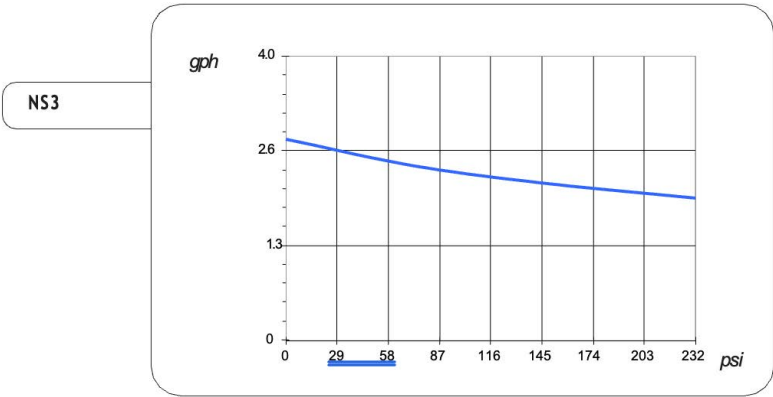
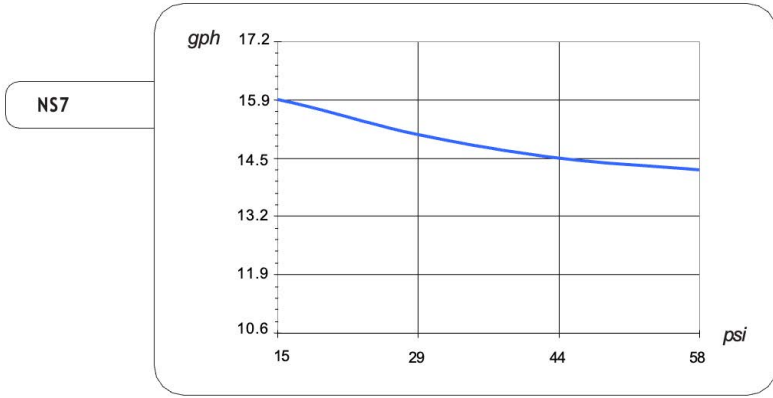

## **8.0 POLICIES AND PROCEDURES**

### **8.1 Manufacturers Limited Product Warranty**

Pulsafeeder, Inc. warrants the NextStep Multifunction Metering Pump to be free of defects in material or workmanship for sixty (60) months from the date of shipment (“Warranty Period”), when used in accordance with the instructions set forth in this manual, and subject to the terms, conditions and limitations set forth herein. During the Warranty Period, in the event of a defect covered by the terms of this Warranty, Pulsafeeder, Inc. will, in its sole discretion either: (i) repair the NextStep or any defective part using either new or refurbished parts that meet the functional specifications for the original NextStep, (ii) replace the NextStep or any defective part with a new or refurbished version of the same model or, if not available, the nearest available model, or (iii) refund the purchase price of the NextStep or defective part.

This Warranty does not cover claims asserted by anyone other than the original purchaser of the NextStep from Pulsafeeder, Inc. or an authorized retailer; claims made outside the Warranty Period (even if the defect occurred during the Warranty Period); or claims made without a dated purchase order or other proof of purchase. It also does not include any costs of installation or removal of the NextStep or any defective part, and in no event shall Pulsafeeder, Inc.’s liability exceed the original purchase price of the Product or the part.

This Warranty does not cover defects, damages or loss caused by: (i) accident (e.g., accidental physical impact, submersion or exposure to extreme temperatures); (ii) theft or loss of NextStep or any of its components or accessories; (iii) abuse, misuse, neglect or failure to observe any and all instructions contained in the instruction manual furnished at the time of original purchase; (iv) acts of nature such as fire, flood, water damage, lightning, power surges (or similar electrical abnormalities), earthquake or tornado; (v) interference from other equipment or incompatibility with other products; (vi) battery leakage or malfunction; or (vii) alteration, modification, disassembly, tampering or repair by anyone other than Pulsafeeder, Inc. or an authorized service provider. It also does not cover normal wear and tear, normal depletion of consumable parts, or cosmetic damage that does not impact the functionality of the Product, such as scratches or stains, or damage that occurs during shipment or handling.

This Warranty does not cover any wear items and supplied accessories or any other products that may be used with NextStep. It does not cover the Product’s packaging or packing materials. And it does not cover installation, removal, setup, adjustment, maintenance, or related cleaning. Replaceable liquid end parts, except for the PTFE diaphragm, such as the head assembly, o-rings, foot valves and injection valves are expendable and are not covered by any warranty either expressed or implied.

For instructions on how to obtain service under this Limited Warranty, please contact Pulsafeeder, Inc. at 27101 Airport Rd., Punta Gorda, FL, USA, (941)575-3800, [ppgpulsaspo.cs@idexcorp.com](mailto:ppgpulsaspo.cs@idexcorp.com). Our customer service team may ask you some questions to determine whether your Product is eligible for warranty service. If we determine that your Product exhibits a covered defect, we will, at our option, repair or replace the Product and ship it to you at our cost or refund you the purchase price of the NextStep. If your Product does not exhibit a covered defect, or if it is otherwise ineligible for service under this Warranty,

we will make reasonable efforts to return the Product to you at your cost upon request, but we make no guarantees and accept no liability for ineligible Product shipped to us.

If we elect to repair or replace NextStep, the repaired or replaced Product shall continue to be covered under this Warranty for the remaining portion of the original Warranty Period, or for three (3) months from the date the repaired or replaced Product is delivered to you, whichever is longer. Any replaced parts (if the Product is repaired), or the original Product (if a replacement or refund is provided), will not be returned to you and will become the property of Pulsafeeder, Inc.

## **LIMITATION OF LIABILITY**

### LIMITATION OF LIABILITY

The product should only be used for the purposes and in the manner specified in the manual. Failure to follow all instructions for use and heed all safety warnings could result in improper product performance, potential personal injury or safety hazard or property damage.

The manufacturer expressly disclaims and will not be liable for any injury or damages resulting from:

- Failure to read and follow all instructions for use and safety warnings contained in this manual,
- Use of the product for any purpose other than its intended use, or in any manner inconsistent with the instructions for use, as set forth in this manual,
- Installation, maintenance of use of the product by untrained or unqualified persons or persons who have not read and fully understood the instructions for use and safety warnings in this manual
- Technical modifications, conversions, repair, disassembly or other alteration of the product, unless performed by the manufacturer or its authorized service personnel,
- Use or installation of parts or materials other than those [recommended in this manual or] that were supplied with the product by the manufacturer.

## **8.2 Returns**

Contact our Customer Service Department by mail, phone or email:

Pulsafeeder, Inc. at 27101 Airport Rd., Punta Gorda, FL, USA

(941)575-3800

[ppgpulsaspo.cs@idexcorp.com](mailto:ppgpulsaspo.cs@idexcorp.com)

We will issue a Return Authorization (RA) number for all returns. The following information will be required:

1. Billing and a ship-to address.
2. Model and serial number.
3. Contact name and phone number.
4. Reason for return.
5. Purchase order (where applicable).

The RA number must appear on the outside of the shipping carton. All material must be returned freight prepaid. All merchandise must be properly packaged and free of any corrosive, toxic or otherwise hazardous chemical. All items returned must reference the Return Authorization number.

## **8.3 Credits**

No Product will be accepted beyond six months after date of shipment from the factory. Only unused and undamaged Product will be accepted for return to stock. All credits are based on acceptance of materials as new and unused by our inspection personnel. A restocking fee will apply. All Product returned for credit must have a RA number and be returned freight prepaid.







Order Online: [www.PumpCatalog.com](http://www.PumpCatalog.com)



**Disposal of end-of-life equipment by users**

This symbol warns you not to dispose of the product with normal waste. Respect human health and the environment by giving the discarded equipment to a designated collection center for the recycling of electronic and electrical equipment. For more information visit the online site.



When dismantling a pump please separate material types and send them according to local recycling disposal requirements. We appreciate your efforts in supporting your local Recycle Environmental Program. Working together we'll form an active union to assure the world's invaluable resources are conserved.

---